

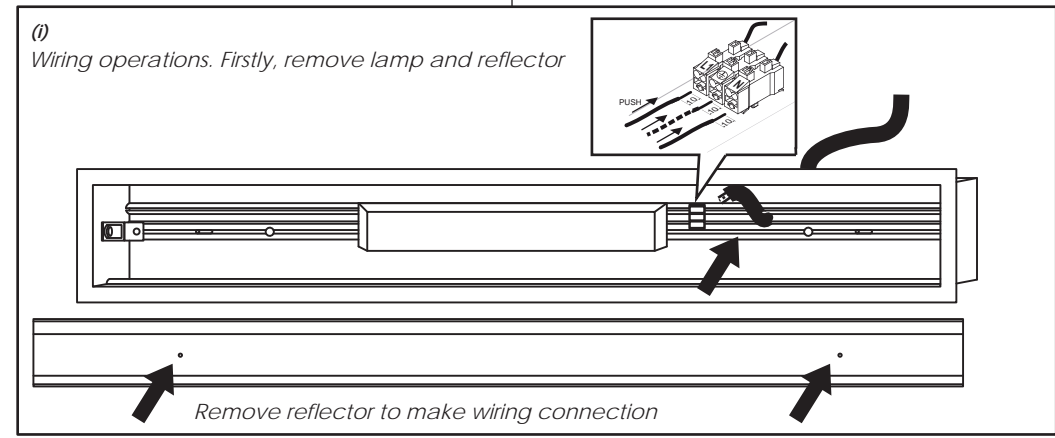

NOTUS 16 STATUS DOUBLE SATIN

INSTALLATION INSTRUCTIONS FOR LUMINAIRE NOTUS 16 STATUS DOUBLE SATIN

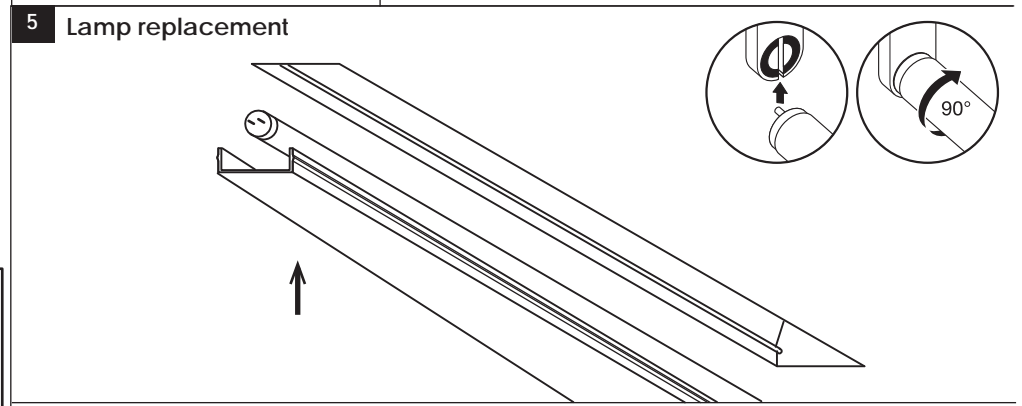
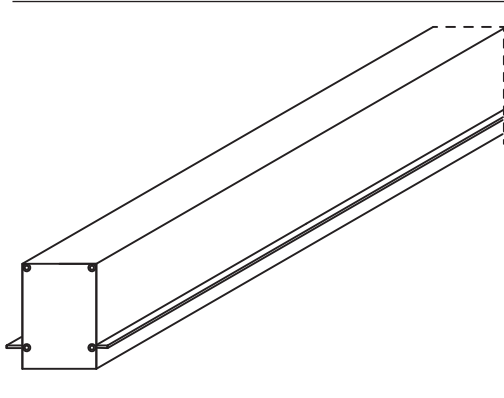
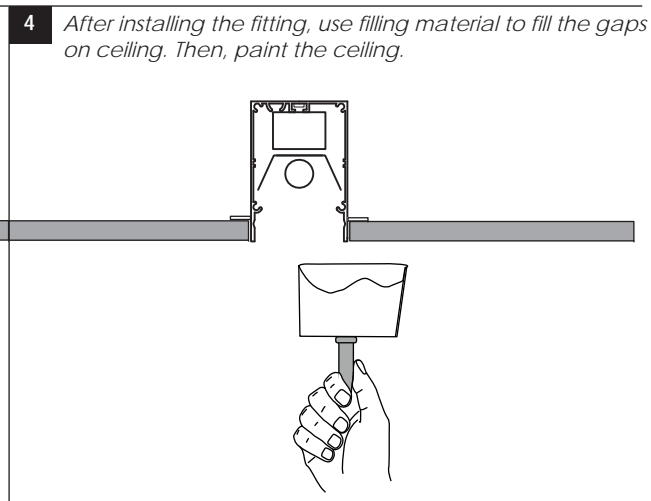
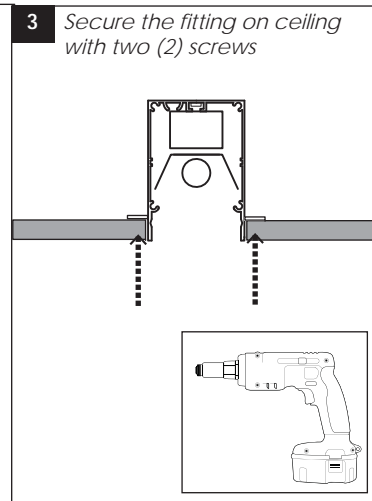
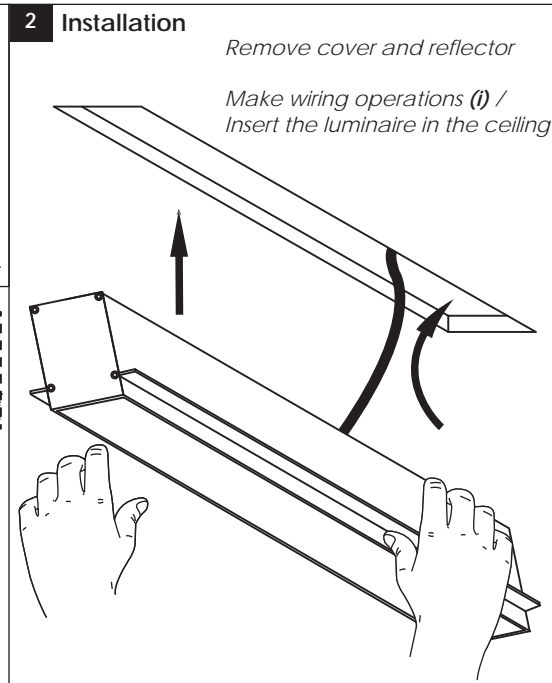
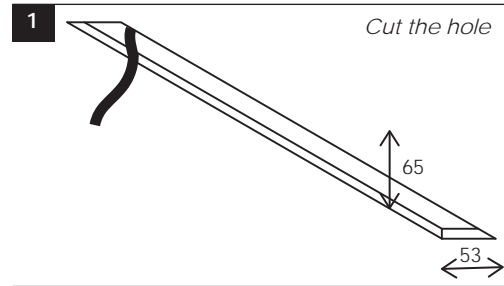

USER INSTRUCTIONS

- The installation of the unit must be done by a qualified electrician.
- The unit must be earthed in case an earth connecting point exists.
- Ensure that the mains is switched off during servicing.
- Do not use bulb(s) bigger than the indicated on units name-plate or packaging.
- Ensure that after the installation, the unit is properly fixed and the cable clamps (if exist) are well tightened.
- Manufacturer will not accept liability for injury or damage resulting from incorrect use or installation
- The unit is not intended to operate in loop connection.
- Wall plugs and terminals are not included.

 Last updated: September 2014